

EAA Chapter 1000 Standardized Work Tables

Bob Waldmiller

(Originally published June 1992)

Revised/updated by Russ Erb

Several articles have been written in a number of publications on the subject of setting up a workshop in which to assemble your homebuilt project. Most of these focus on how much space you'll need in your hangar, garage, basement, den, or living room (pick one). Likewise, there is always some discussion on the kind of tools you'll need to build your metal, wood, composite, or tube and rag aircraft. The design of your aircraft will pretty much dictate what kind of hand and power tools you'll need but there is always one common tool that can be used in any workshop—a decent work bench or work table.

A good looking airplane starts with decent tooling and although you can make cheap expendable tooling for one-time applications such as jigs and fixtures, you'll no doubt agree that a sturdy work table is an absolute must. I've seen tables made from a sheet of plywood or particle board over a couple of saw-horses and the mere flimsiness of the work surface quickly leads to severe onsets of the love-hate relationship with the airplane—most of it spent in the hate mode—and it's tough to do quality workmanship when you're that frustrated.

Remember, a good looking airplane starts with decent tooling. On one of my previous projects I used work tables built out of light weight angle iron with holes in it all bolted together. We used a 5/8ths inch particle board top covered with Formica for the work surface and gave it adjustable legs for leveling. A neat idea and the tables sure looked nice but they were a little too wide (36") and a little too high (36"). One problem we had was the work surface was a bit too flimsy so we put stiffeners under it—but even then we didn't want to climb on the tables or put any heavy loads on it.

When we Bondo'ed the Defiant canard jigs to the table, we found that the table itself contributed to our difficulties in getting everything lined up. Our solution was to adopt some basic etiquette, like keeping our elbows and feet off the table. Not a very practical solution was it? Let's face it, sturdy worktables are a must for any project and a good-looking airplane starts with decent tooling.

When Norm Howell and I discussed the subject of building work benches for the infamous "Hangar 308," we somehow managed to engage our minds simultaneously and from the synergy of both our brain cells crashing together, we hit upon the idea of standardized general-purpose work tables. "Standardized" such that all our worktables are built to the same general dimensions—especially the 33-3/4 inch table height and "general-purpose" such that our tables are not aircraft specific. By that I mean that our tables are not 10- or 15-foot long but rather a relatively short 5 feet in length. It is a lot easier to bolt our tables together than to disassemble a larger one. Besides, what do you do with a 15-foot long bench after you've built that canard or fuselage? Long tables don't fit well in small workshops and they're tough to give away. In contrast, our 2'-by-5' work tables can be put just about anywhere and used for almost anything. They are also sturdy enough to climb on without fear of disturbing jig or fixture alignments.

Addendum by Russ Erb

I'd like to submit for your consideration the EAA Chapter 1000 standardized work table. These tables take a totally different approach than the one shown in the Bearhawk newsletter. The

crux of the idea is that instead of using one large table, use several standardized smaller tables that can be clamped or bolted together and individually leveled.

I'm building in a one car garage that measures 20'6" x 13'10", of which I lost 2 feet of width to the requisite shelves. Like Sean, an 18' x4' table would take a huge chunk out of that, especially at the ends. Additionally, I am not part gorilla, and thus have a hard time reaching across a 4' table (comfortably reaching the middle isn't easy either). However, reaching across a 2' table is no sweat.

The Chapter 1000 standard work table is 2' x 5' in dimensions, and 33-3/4" high. I can use them separately to build small parts, such as the wing ribs. For the wing spars, which are just under 14' long, I will clamp 3 tables together for a 2' x 15' table. When it is time to assemble the wings, I will move the tables out of the way and set up the wing jigs (yes, plural—I plan to do both wings simultaneously—I figure I'll have a better chance of making them identical that way.) For the fuselage, I'll clamp the three tables (maybe four) together and attach a flat board across the tables for the required width. My initial thought is to use one or two thicknesses of 7/16" chipboard (or OSB). While it doesn't look pretty, it doesn't seem to warp like plywood. This has the additional benefit that I won't care if it gets burn spots while tack welding the fuselage.

After tack welding, remove the boards, which will leave most of the welds exposed for completing. (Actually, I'm thinking of putting the fuselage on a rotating spit to make the welding easier.) My main point is that several small standard tables are more manageable and useful than one big one.

Something else that we do with our tables is to cover the tables with butcher paper held down around the edges with masking tape. That way, the paper gets messed up, but the table is unharmed. When the paper is really messed up, just replace it. It has the added benefit that you can scribble notes on it, such as measurements. I can never seem to remember them for any length of time any other way.

Now that I've convinced you that you can't live without a couple of these first-class work tables, refer to the following detail drawing and I'll tell you how you can build 'em: \

Step 1: Buy the materials as listed on the drawing. Don't skimp and get cheap wood as the better quality lumber is well worth the investment. Powerdrive screws work real well for fastening the plywood to the two-by-fours but use flat head Phillips wood screws for fastening the two-by-fours together. You might want to buy a #10 countersink bit for your drill too. In 1992 dollars all this works out to approximately \$47 per table. (*About \$60 per table in 1997*)

Step 2: Cut the plywood to size. You'll probably want to cut across the 4' dimension first, leaving a 3' x 4' piece. Be careful on the next cut as the saw kerf will use up an eighth of an inch or more so the 24" dimension of both the top plywood and the shelf plywood will be a little undersize. Build the upper frame first and cover it on one side with the 3/4" plywood. You literally build this table from the top down and it needs to be flat and square. Use 3" long #10 wood screws and glue to fasten the two-by-fours together and use 1-1/2" long #8 construction screws along with the glue to fasten the plywood top in place.

Step 3: Turn the top frame over and fasten the four legs in place with 3" long wood screws and glue. Make sure everything is as square as possible then fasten the 17-1/2" long leg doublers on the outside of each leg with glue and 2" long wood screws.

Step 4: With the table still upside-down, build the lower shelf frame in place on the table legs. Again glue and screw everything in place with the 3" long #10 wood screws. Then add the remaining 8.5" long leg doubler to the table legs. Since the lumber dimensions vary, it is best to mark the 8.5" long doublers in place before cutting them to length. That way you'll get a good custom fit on the doublers.

Step 5: Turn the table upright and fasten the lower shelf plywood in place with the 1-1/2" long construction screws. Finally, glue and nail the edge molding in place with 3d finishing nails. This gives the table a nice finished appearance and will keep those nasty wood slivers out of your hands.

And that's all there is to it! If you take your time and do a good job these tables will last forever- which is exactly the kind of work table that you want. Norm and I have built five tables just like the one described above and have been very happy with them. Our airplanes even look a bit better sitting on them! Like I've been saying all along, a good-looking airplane starts with decent tooling!

EAA Chapter 1000 Standardized Work Table Plans

Bob Waldmiller

Originally published June 1992

[Building Instructions](http://www.eaa1000.av.org/technical/worktabl/worktabl.htm) - <http://www.eaa1000.av.org/technical/worktabl/worktabl.htm>

BILL OF MATERIALS (to build 2 tables)

- (1) 3/4" x 4' x 8' Sanded Exterior Plywood
 - (1) 1/2" x 4' x 8' Plywood
 - (14) 2" x 4" x 8' Premium Studs
 - (4) 1/4" x 3/4" x 8' Pine Flat Screen Moulding
 - (80) #10 x 3" Wood Screws
 - (50) #10 x 2-1/2" Wood Screws
 - (50) #8 x 1-1/2" Construction Screws
 - (1) Box of 3d Finishing Nails
 - (1) 16 oz Elmer's Carpenter's Wood Glue
- (See cutting schedule below)

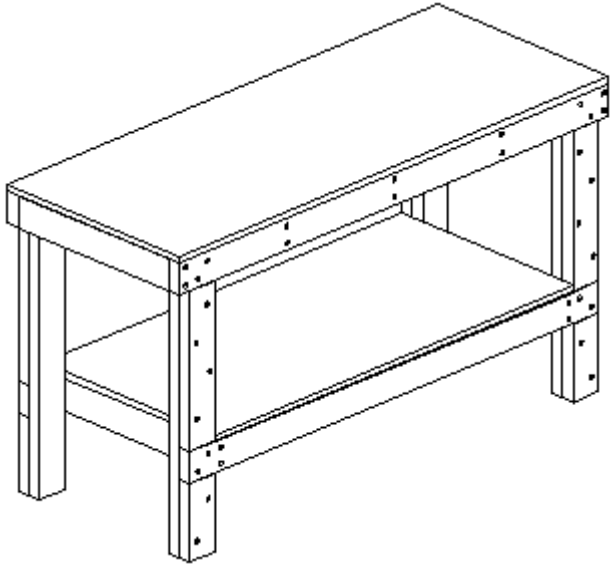

Fully assembled work table

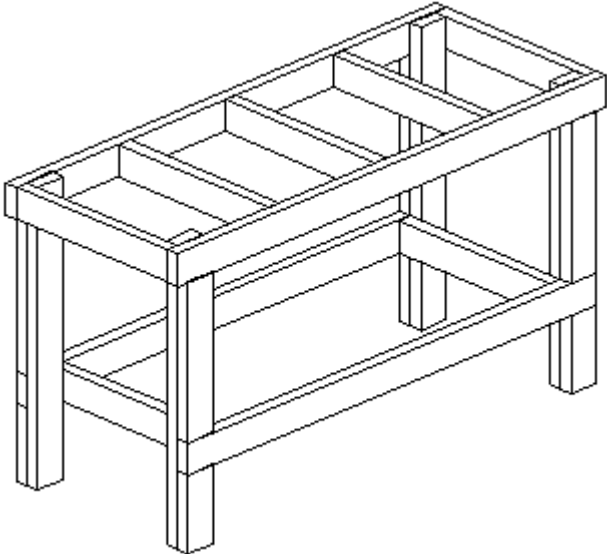

Assembled work table shown with the plywood removed for clarity

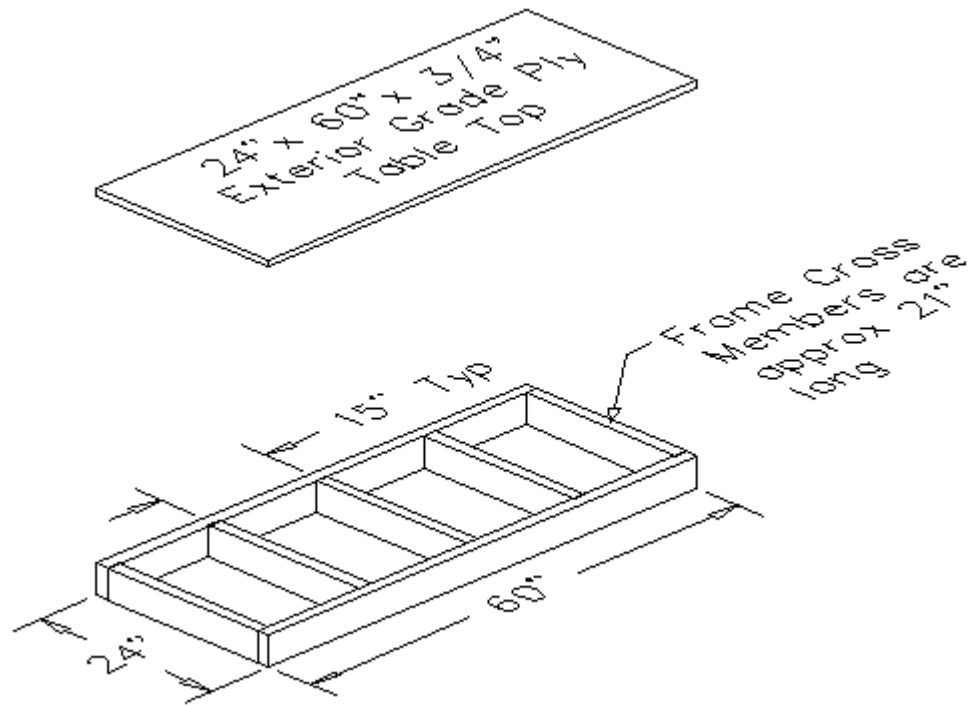

Exploded table top

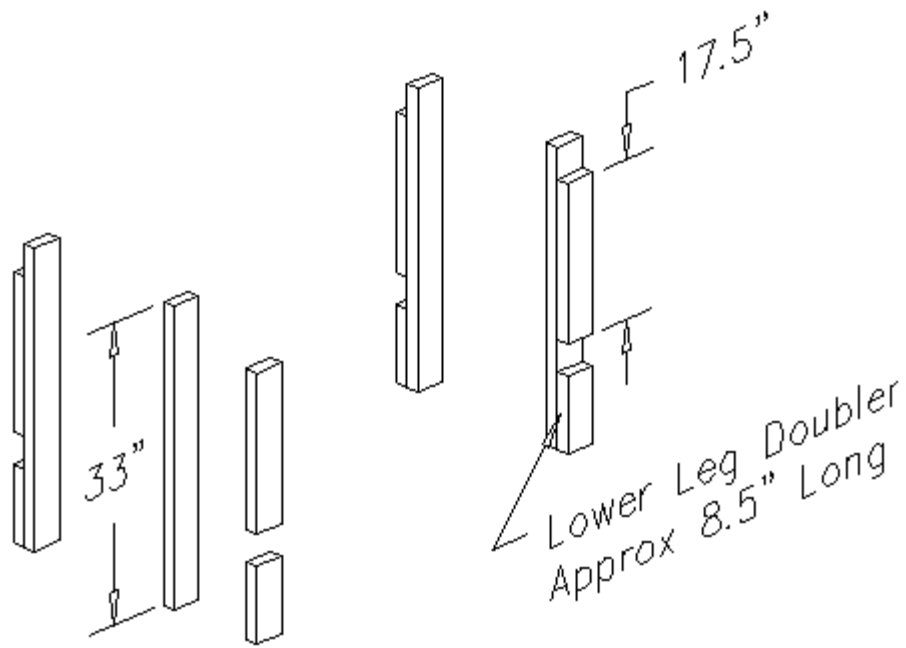
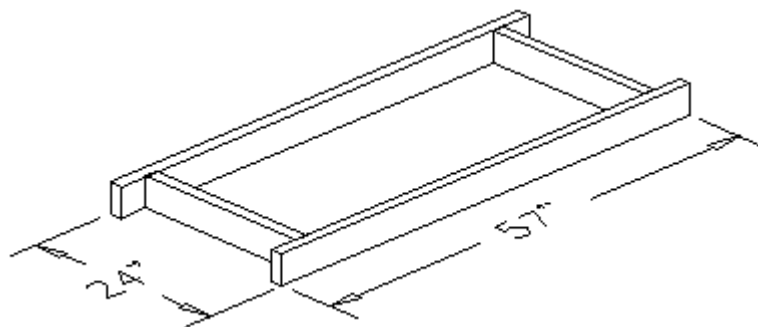
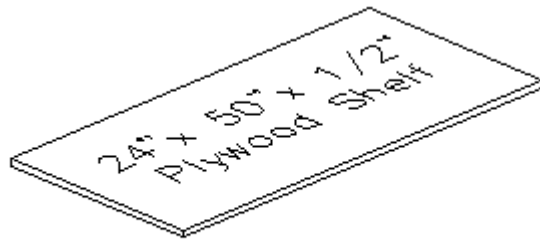

Table legs



Exploded lower shelf
2x4 Cutting Schedule

| 2x4 # | Cut to lengths | | | | |
|-------|----------------|-------|-------|-------|-------|
| 1 | 60" | 33" | | | |
| 2 | 60" | 33" | | | |
| 3 | 60" | 33" | | | |
| 4 | 60" | 33" | | | |
| 5 | 57" | 33" | | | |
| 6 | 57" | 33" | | | |
| 7 | 57" | 33" | | | |
| 8 | 57" | 33" | | | |
| 9 | 17.5" | 17.5" | 17.5" | 17.5" | 17.5" |
| 10 | 17.5" | 17.5" | 17.5" | 21" | 21" |
| 11 | 21" | 21" | 21" | 21" | 8.5"* |
| 12 | 21" | 21" | 21" | 21" | 8.5"* |
| 13 | 21" | 21" | 21" | 21" | 8.5"* |
| 14 | 8.5"* | 8.5"* | 8.5"* | 8.5"* | 8.5"* |

*Cut to match lower legs

[Return to top](#)



[EAA Chapter 1000 Home Page - http://www.eaa1000.av.org/index.htm](http://www.eaa1000.av.org/index.htm)

E-Mail: [Web Site Director Russ Erb at erbman@pobox.com](mailto:Web_Site_Director_Russ_Erb_at_erbman@pobox.com)

URL: <http://www.eaa1000.av.org/technicl/worktabl/tablefig.htm>

Contents of The Leading Edge and these web pages are the viewpoints of the authors. No claim is made and no liability is assumed, expressed or implied as to the technical accuracy or safety of the material presented. The viewpoints expressed are not necessarily those of Chapter 1000 or the Experimental Aircraft Association.

Revised—10 July 1997